

Symphony Plus™ ice and water dispenser

C/E 12 CI series countertop with Chewblet® ice machine



Shown with SensorSAFE™



SensorSAFE infrared dispense



SensorSAFE not recommended for use with clear containers or for applications in direct sunlight

Model configurations				
Ice storage capacity	Dispense	Ice machine cooling	Voltage V/Hz	Item number
5.4 kg (12 lb)	Lever	air	220/60	C12CI425A-L
	Lever	air	230/50	E12CI425A-L
	SensorSAFE	air	220/60	C12CI425A-S
	SensorSAFE	air	230/50	E12CI425A-S

Ice-only available, add -I
Example: E12CI425A-LI

Ice production		
Temperatures air/water	21/10 C (70/50 F)	32/21 C (90/70 F)
Air-cooled	186.1 kg (410 lb)	140.7 kg (310 lb)
Energy consumption per 45.4 kg (100 lb) ice	N/A	6.0 kWh air-cooled
Water consumption	45.4 L (12.0 gal) of potable water per 45.4 kg (100 lb) of ice	

Features

Narrow, 40.9 cm (16.12 ") width

5.4 kg (12 lb) ice storage capacity

Integral air-cooled ice machine with up to 186 kg (410 lb) daily production of Chewblet ice

- soft, chewable, compressed nugget ice is preferred over cubes ¹ and is ideal for patient care
- Quiet Night™ sleep mode turns off ice machine when idle

Designed with sanitation in mind

- automatic self-flushing of ice machine removes impurities
- drain cup provides internal air gap for added protection of food zone components from drain line contaminants
- Agion® silver-based antimicrobial provides protection of key ice and water contact components ²
- one-hand lever or SensorSAFE infrared ice dispense

Dependable design, easy to service and clean

- cleaning and sanitizing of entire machine takes only 1 hour
- LED control board provides at-a-glance machine status
- panels are easily removed for accessibility to all components
- ice machine parts are common across all Symphony Plus dispensers
- stainless steel evaporator and auger deliver long life

Environmentally responsible

- continuous ice making process uses less electricity and water

Durable, attractive dispenser

- stainless steel cabinet with accent trim
- poly drain pan, grille and dispenser lid are corrosion-resistant

Easy installation

- comes fully assembled and installs with three easy connections – electric, water and drain

Warranty

- 3 years parts and labor, 5 years compressor parts³

Accessories

Base stand with or without factory installed water filter (refer to form# 7010)

10.16 cm (4.00") leg kit (item# AF10LBLEGS)

Pressurized water sanitizing kits (refer to form# 6830)

Water filters (refer to form# 9905)

Additional Symphony Plus accessories (refer to price list)



(716) 783-9659
info@purewaterwny.com
www.purewaterwny.com

Specification

Ice storage capacity	5.4 kg (12 lb)
W1 Width	40.9 cm (16.12")
W2 Width, base stand accessory	44.4 cm (17.5")
D1 Depth, entire dispenser	59.7 cm (23.50")
D2 Depth, drain pan	13.97 cm (5.50")
D3 Depth, base stand accessory	55.9 cm (22.00")
H1 Height, dispenser	82.6 cm (32.50")
H2 Dispense height clearance	23.83 cm (9.38")
H3 Height, base stand accessory	83.8 cm (33.00")
H4 Height, leg kit accessory	93.1 cm (36.64 ")
Ventilation clearance	15.24 cm (6.00") top and right side
Service clearance	30.5 cm (12.00") top
Utility connection location	through back or bottom
C1 220 V/60/1 ("C" models) / 230 V/50/1 ("E" models) electrical	5.5 amps, 0.8 kW 2.4 m (8') cord only
C2 Potable water inlet	3/8" FPT
C3 Drain	3/4" MPT
Ice production at 70 F (21 C) air, 50 F (10 C) water	60 Hz models – 186 kg (410 lb) 50 Hz models – 154 kg (339 lb)
Ice production at 90 F (32 C) air, 70 F (21 C) water	60 Hz models – 145 kg (319 lb) 50 Hz models – 120 kg (264 lb)
Heat rejection	5000 BTU/hr
Air temperature	10 - 38 C (50 -100 F)
Water temperature	7 - 32 C (45 - 90 F)
Potable water pressure	69 - 483 kpa (10 - 70 psi)
Refrigerant	R404a for 60 Hz models R449a for 50 Hz models
Approximate net weight	65 kg (144 lb)
Approximate ship weight	90 kg (199 lb)
Approximate ship weight, base stand accessory	36 kg (80 lb)
NOTE: For indoor use only	

SHORT FORM SPECIFICATION:(Choose one) ___ Ice and water or ___ ice-only dispenser to be Follett® automatic load in countertop configuration, with 5.4 kg (12 lb) of storage and separate ice and water chutes. Air-cooled ice machine to produce chewable nugget ice. Ice machine equipped with automatic self-flushing and Quiet Night sleep mode. Dispenser to have automatic bin level control to start and stop ice machine. Storage area to be insulated with CARB compliant non-HFC foam. 2.4 m (8') cord only. 230 V models CE and EU food contact compliant.

Dimensional drawing

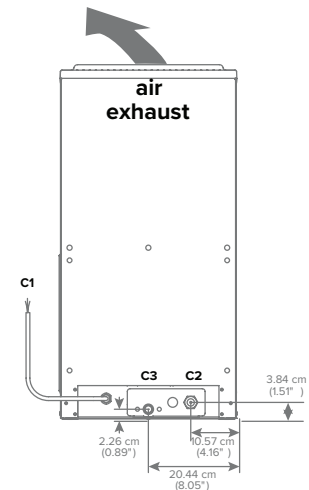
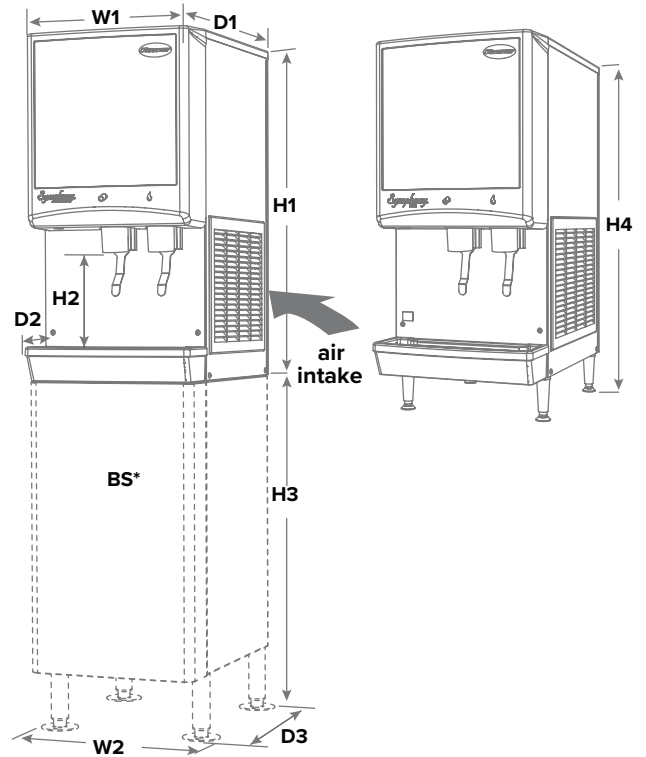

BS* – Base stand sold separately; measurements shown are with base stand legs at lowest position.

See dispenser detail sheet, form# 6675, for counter cut outs .

- 1 Independent third party studies. Contact Follett for details.
 - 2 Disclaimer: Antimicrobial protection is limited to the treated components and does not treat water or ice.
 - 3 Refer to price list for additional warranty information.
- Agion is a registered trademark of Sciessent LLC.
 SYMPHONY PLUS, SENSORSAFE and QUIET NIGHT are trademarks of Follett LLC.
 CHEWBLET and FOLLETT are registered trademarks of Follett LLC, registered in the US.
 Follett reserves the right to change specifications at any time without obligation. Certifications may vary depending on country of origin.